

**Explosion Proof NEMA 143T-445T - TEFC
Cast Iron Construction**



2574233



CC134B

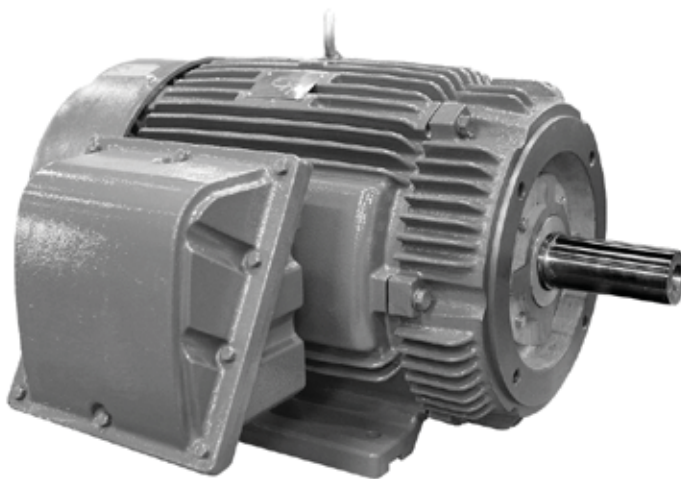
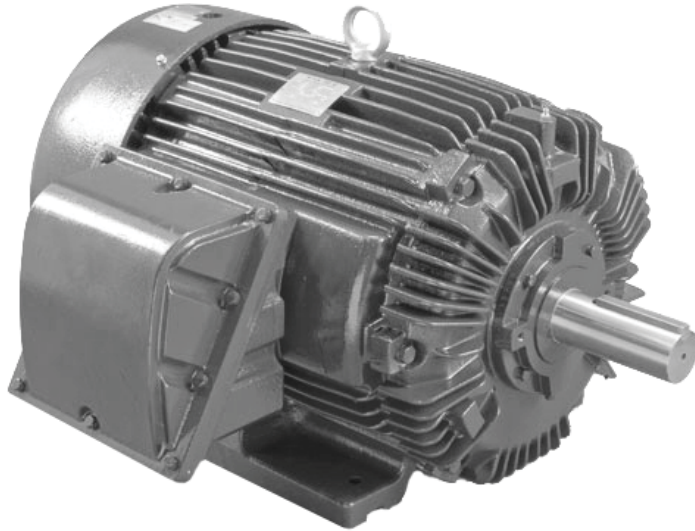

Premium Efficient Three Phase NEMA Explosion Proof Motors. Foot Mount or C-Face Mount, Totally Enclosed Fan Cooled. Features Include:

- NEMA MG1 part 31 inverter duty UL & CSA certified 20:1 variable torque
- UL certified 5:1 constant torque
- CSA certified 10:1 constant torque
- UL/CSA approved Div I, Class I, Group C & D: 143T - 256T; Div I, Class I, Group D: 284T & above
- UL/CSA approved Div I, Class II Groups E, F & G. T3B temperature code
- Service factor 1.15 sine wave power
- IP55 degree of protection
- NEMA design B
- Class F insulation
- Dual rated 60/50 Hz
- Normally closed thermostats— One per phase
- Sealed ball bearings 140 - 280T
- Regreasable bearings 320T and above
- Warranty: 3 years

Single Phase

Fractional 5/6/5/6C

NEMA Aluminum

NEMA Cast Iron

NEMA Explosion Proof

Close Coupled Pump Motor

NEMA 2 Speed Motor

NEMA Brake Motor

Notes:
TH - Thermostats

Single Phase

Fractional
56/56C

NEMA
Aluminum

NEMA
Cast Iron

NEMA
Explosion Proof

Close Coupled
Pump Motor

NEMA
2 Speed Motor

NEMA
Brake Motor

HP	RPM	Frame	Voltage	P/N	List	FL Eff.	C Dim. (IN)	S.F. 60 Hz	FL Amps	LBS	Notes
1	1800	143T	230/460 V	PX4N001-2	\$682	85.5	12.55	1.15	1.60	62	TH
	1800	143T	575 V	PX4N001-5	\$682	85.5	12.55	1.15	1.20	62	TH
	1200	145T	230/460 V	PX6N001-2	\$757	82.5	13.54	1.15	1.70	70	TH
	1200	145T	575 V	PX6N001-5	\$757	82.5	13.54	1.15	1.30	70	TH
1.5	3600	143T	230/460 V	PX2N1.5-2	\$736	84	12.55	1.15	1.90	62	TH
	3600	143T	575 V	PX2N1.5-5	\$736	84	12.55	1.15	1.50	62	TH
	1800	145T	230/460 V	PX4N1.5-2	\$736	86.5	13.54	1.15	2.10	70	TH
	1800	145T	575 V	PX4N1.5-5	\$736	86.5	13.54	1.15	1.70	70	TH
	1200	182T	230/460 V	PX6N1.5-2	\$893	87.5	14.89	1.15	2.50	108	TH
	1200	182T	575 V	PX6N1.5-5	\$893	87.5	14.89	1.15	2.00	108	TH
2	3600	145T	230/460 V	PX2N002-2	\$786	85.5	13.54	1.15	2.50	70	TH
	3600	145T	575 V	PX2N002-5	\$786	85.5	13.54	1.15	2.00	70	TH
	1800	145T	230/460 V	PX4N002-2	\$794	86.5	13.54	1.15	2.70	70	TH
	1800	145T	575 V	PX4N002-5	\$794	86.5	13.54	1.15	2.20	70	TH
	1200	184T	230/460 V	PX6N002-2	\$1,029	88.5	15.91	1.15	3.00	120	TH
	1200	184T	575 V	PX6N002-5	\$1,029	88.5	15.91	1.15	2.40	120	TH
3	3600	182T	230/460 V	PX2N003-2	\$917	87.5	14.89	1.15	3.50	108	TH
	3600	182T	575 V	PX2N003-5	\$917	87.5	14.89	1.15	2.80	108	TH
	1800	182T	230/460 V	PX4N003-2	\$963	89.5	14.89	1.15	3.80	108	TH
	1800	182T	575 V	PX4N003-5	\$963	89.5	14.89	1.15	3.10	108	TH
	1200	213T	230/460 V	PX6N003-2	\$1,472	89.5	18.26	1.15	3.90	187	TH
	1200	213T	575 V	PX6N003-5	\$1,472	89.5	18.26	1.15	3.10	187	TH
5	3600	184T	230/460 V	PX2N005-2	\$1,142	88.5	15.91	1.15	5.80	120	TH
	3600	184T	575 V	PX2N005-5	\$1,142	88.5	15.91	1.15	4.60	120	TH
	1800	184T	230/460 V	PX4N005-2	\$1,142	89.5	15.91	1.15	6.20	120	TH
	1800	184T	575 V	PX4N005-5	\$1,142	89.5	15.91	1.15	4.90	120	TH
	1200	215T	230/460 V	PX6N005-2	\$1,716	90.2	19.76	1.15	6.40	211	TH
	1200	215T	575 V	PX6N005-5	\$1,716	90.2	19.76	1.15	5.10	211	TH
7.5	3600	213T	230/460 V	PX2N7.5-2	\$1,418	89.5	18.26	1.15	9.00	187	TH
	3600	213T	575 V	PX2N7.5-5	\$1,418	89.5	18.26	1.15	7.20	187	TH
	1800	213T	230/460 V	PX4N7.5-2	\$1,495	91.7	18.26	1.15	8.80	187	TH
	1800	213T	575 V	PX4N7.5-5	\$1,495	91.7	18.26	1.15	7.00	187	TH
	1200	254T	230/460 V	PX6N7.5-2	\$2,047	91	23.78	1.15	9.40	330	TH
	1200	254T	575 V	PX6N7.5-5	\$2,047	91	23.78	1.15	7.50	330	TH
10	3600	215T	230/460 V	PX2N010-2	\$1,674	90.2	19.76	1.15	11.90	211	TH
	3600	215T	575 V	PX2N010-5	\$1,674	90.2	19.76	1.15	9.50	211	TH
	1800	215T	230/460 V	PX4N010-2	\$1,716	91.7	19.76	1.15	11.70	211	TH
	1800	215T	575 V	PX4N010-5	\$1,716	91.7	19.76	1.15	9.30	211	TH
	1200	256T	230/460 V	PX6N010-2	\$2,452	91	25.52	1.15	12.60	376	TH
	1200	256T	575 V	PX6N010-5	\$2,452	91	25.52	1.15	10.10	376	TH
15	3600	254T	230/460 V	PX2N015-2	\$2,188	91	23.78	1.15	16.80	330	TH
	3600	254T	575 V	PX2N015-5	\$2,188	91	23.78	1.15	13.40	330	TH
	1800	254T	230/460 V	PX4N015-2	\$2,188	92.4	23.78	1.15	17.90	330	TH
	1800	254T	575 V	PX4N015-5	\$2,188	92.4	23.78	1.15	14.30	330	TH
	1200	284T	230/460 V	PX6N015-2	\$3,101	91.7	26.80	1.15	18.50	488	TH
	1200	284T	575 V	PX6N015-5	\$3,101	91.7	26.80	1.15	14.70	488	TH
20	3600	256T	230/460 V	PX2N020-2	\$2,528	91	25.52	1.15	22.40	376	TH
	3600	256T	575 V	PX2N020-5	\$2,528	91	25.52	1.15	17.80	376	TH
	1800	256T	230/460 V	PX4N020-2	\$2,579	93	25.52	1.15	23.60	376	TH
	1800	256T	575 V	PX4N020-5	\$2,579	93	25.52	1.15	18.80	376	TH
	1200	286T	230/460 V	PX6N020-2	\$3,721	91.7	28.30	1.15	24.30	530	TH
	1200	286T	575 V	PX6N020-5	\$3,721	91.7	28.30	1.15	19.40	530	TH

Discount Category **20**

Explosion Proof NEMA 143T-445T - TEFC Foot Mounted - Cast Iron



HP	RPM	Frame	Voltage	P/N	List	FL Eff.	C Dim. (IN)	S.F. 60 Hz	FL Amps	LBS	Notes
25	3600	284TS	230/460 V	PX2N025-2	\$3,175	91.7	25.43	1.15	27.70	488	TH
	3600	284TS	575 V	PX2N025-5	\$3,175	91.7	25.43	1.15	22.20	488	TH
	1800	284T	230/460 V	PX4N025-2	\$3,201	93.6	26.93	1.15	29.40	488	TH
	1800	284T	575 V	PX4N025-5	\$3,201	93.6	26.93	1.15	23.50	488	TH
	1200	324T	230/460 V	PX6N025-2	\$4,949	93	29.93	1.15	30.30	708	TH
	1200	324T	575 V	PX6N025-5	\$4,949	93	29.93	1.15	24.20	708	TH
30	3600	286TS	230/460 V	PX2N030-2	\$3,661	92.4	26.93	1.15	33.00	530	TH
	3600	286TS	575 V	PX2N030-5	\$3,661	92.4	26.93	1.15	26.40	530	TH
	1800	286T	230/460 V	PX4N030-2	\$3,717	93.6	28.30	1.15	35.10	488	TH
	1800	286T	575 V	PX4N030-5	\$3,717	93.6	28.30	1.15	28.00	488	TH
	1200	326T	230/460 V	PX6N030-2	\$5,844	93	31.42	1.15	36.40	781	TH
	1200	326T	575 V	PX6N030-5	\$5,844	93	31.42	1.15	29.10	781	TH
40	3600	324TS	230/460 V	PX2N040-2	\$4,931	93	28.43	1.15	44.30	708	TH
	3600	324TS	575 V	PX2N040-5	\$4,931	93	28.43	1.15	35.40	708	TH
	1800	324T	230/460 V	PX4N040-2	\$4,953	94.1	29.93	1.15	46.60	708	TH
	1800	324T	575 V	PX4N040-5	\$4,953	94.1	29.93	1.15	37.20	708	TH
	1200	364T	230/460 V	PX6N040-2	\$7,659	94.1	32.57	1.15	46.30	946	TH
	1200	364T	575 V	PX6N040-5	\$7,659	94.1	32.57	1.15	37.00	946	TH
50	3600	326TS	230/460 V	PX2N050-2	\$6,044	93.6	29.92	1.15	55.00	781	TH
	3600	326TS	575 V	PX2N050-5	\$6,044	93.6	29.92	1.15	43.90	781	TH
	1800	326T	230/460 V	PX4N050-2	\$5,861	64.5	31.42	1.15	57.90	781	TH
	1800	326T	575 V	PX4N050-5	\$5,861	64.5	31.42	1.15	46.30	781	TH
	1200	365T	230/460 V	PX6N050-2	\$9,181	94.1	33.55	1.15	59.60	1019	TH
	1200	365T	575 V	PX6N050-5	\$9,181	94.1	33.55	1.15	47.60	1019	TH
60	3600	364TS	230/460 V	PX2N060-2	\$7,540	93.6	30.44	1.15	64.50	946	TH
	3600	364TS	575 V	PX2N060-5	\$7,540	93.6	30.44	1.15	51.60	946	TH
	1800	364T	230/460 V	PX4N060-2	\$7,647	95	32.57	1.15	67.20	946	TH
	1800	364T	575 V	PX4N060-5	\$7,647	95	32.57	1.15	53.70	946	TH
	1200	404T	230/460 V	PX6N060-2	\$10,643	94.5	36.50	1.15	69.10	1408	TH
	1200	404T	575 V	PX6N060-5	\$10,643	94.5	36.50	1.15	55.30	1408	TH
75	3600	365TS	230/460 V	PX2N075-2	\$9,829	93.6	31.42	1.15	80.70	1019	TH
	3600	365TS	575 V	PX2N075-5	\$9,829	93.6	31.42	1.15	64.50	1019	TH
	1800	365T	230/460 V	PX4N075-2	\$9,164	95.4	33.55	1.15	83.60	1019	TH
	1800	365T	575 V	PX4N075-5	\$9,164	95.4	33.55	1.15	66.90	1019	TH
	1200	405T	230/460 V	PX6N075-2	\$11,350	94.5	37.99	1.15	85.90	1408	TH
	1200	405T	575 V	PX6N075-5	\$11,350	94.5	37.99	1.15	68.70	1408	TH
100	3600	405TS	230/460 V	PX2N100-2	\$12,795	94.5	34.99	1.15	108.00	1408	TH
	3600	405TS	575 V	PX2N100-5	\$12,795	94.5	34.99	1.15	86.10	1408	TH
	1800	405T	230/460 V	PX4N100-2	\$11,350	95.4	37.99	1.15	109.00	1408	TH
	1800	405T	575 V	PX4N100-5	\$11,350	95.4	37.99	1.15	87.20	1408	TH
	1200	444T	230/460 V	PX6N100-2	\$15,059	95	44.40	1.15	118.00	1650	TH
	1200	444T	575 V	PX6N100-5	\$15,059	95	44.40	1.15	94.40	1650	TH
125	3600	444TS	460 V	PX2N125-9	\$16,227	95	40.65	1.15	137.00	1650	TH
	3600	444TS	575 V	PX2N125-5	\$16,227	95	40.65	1.15	109.00	1650	TH
	1800	444T	460 V	PX4N125-9	\$15,063	95.4	44.40	1.15	139.00	1650	TH
	1800	444T	575 V	PX4N125-5	\$15,063	95.4	44.40	1.15	111.00	1650	TH
	1200	445T	460 V	PX6N125-9	\$19,129	95	46.40	1.15	184.00	1720	TH
	1200	445T	575 V	PX6N125-5	\$19,129	95	46.40	1.15	147.00	1720	TH
150	3600	445TS	460 V	PX2N150-9	\$18,822	95	42.65	1.15	164.00	1720	TH
	3600	445TS	575 V	PX2N150-5	\$18,822	95	42.65	1.15	131.40	1720	TH
	1800	445T	460 V	PX4N150-9	\$19,029	95.8	46.40	1.15	165.00	1720	TH
	1800	445T	575 V	PX4N150-5	\$19,029	95.8	46.40	1.15	131.70	1720	TH

Discount Category **20**

Single Phase
Fractional 56/56C
NEMA Aluminum
NEMA Cast Iron
NEMA Explosion Proof
Close Coupled Pump Motor
NEMA 2 Speed Motor
NEMA Brake Motor

Single Phase

Fractional
56/56C

NEMA
Aluminum

NEMA
Cast Iron

NEMA
Explosion Proof

Close Coupled
Pump Motor

NEMA
2 Speed Motor

NEMA
Brake Motor

HP	RPM	Frame	Voltage	P/N	List	FL Eff.	C Dim. (IN)	S.F. 60 Hz	FL Amps	LBS	Notes
1	1800	143TC	230/460 V	PX4N001-2C	\$862	85.5	12.55	1.15	1.60	77	TH
	1800	143TC	575 V	PX4N001-5C	\$862	85.5	12.55	1.15	1.20	77	TH
	1200	145TC	230/460 V	PX6N001-2C	\$934	82.5	13.54	1.15	1.70	85	TH
	1200	145TC	575 V	PX6N001-5C	\$934	82.5	13.54	1.15	1.30	85	TH
1.5	3600	143TC	230/460 V	PX2N1.5-2C	\$913	84	12.55	1.15	1.90	77	TH
	3600	143TC	575 V	PX2N1.5-5C	\$913	84	12.55	1.15	1.50	77	TH
	1800	145TC	230/460 V	PX4N1.5-2C	\$913	86.5	13.54	1.15	2.10	85	TH
	1800	145TC	575 V	PX4N1.5-5C	\$913	86.5	13.54	1.15	1.70	85	TH
	1200	182TC	230/460 V	PX6N1.5-2C	\$1,177	87.5	14.89	1.15	2.50	133	TH
	1200	182TC	575 V	PX6N1.5-5C	\$1,177	87.5	14.89	1.15	2.00	133	TH
2	3600	145TC	230/460 V	PX2N002-2C	\$964	85.5	13.54	1.15	2.50	85	TH
	3600	145TC	575 V	PX2N002-5C	\$964	85.5	13.54	1.15	2.00	85	TH
	1800	145TC	230/460 V	PX4N002-2C	\$973	86.5	13.54	1.15	2.70	85	TH
	1800	145TC	575 V	PX4N002-5C	\$973	86.5	13.54	1.15	2.20	85	TH
	1200	184TC	230/460 V	PX6N002-2C	\$1,313	88.5	15.91	1.15	3.00	145	TH
	1200	184TC	575 V	PX6N002-5C	\$1,313	88.5	15.91	1.15	2.40	145	TH
3	3600	182TC	230/460 V	PX2N003-2C	\$1,202	87.5	14.89	1.15	3.50	133	TH
	3600	182TC	575 V	PX2N003-5C	\$1,202	87.5	14.89	1.15	2.80	133	TH
	1800	182TC	230/460 V	PX4N003-2C	\$1,249	89.5	14.89	1.15	3.80	133	TH
	1800	182TC	575 V	PX4N003-5C	\$1,249	89.5	14.89	1.15	3.10	133	TH
	1200	213TC	230/460 V	PX6N003-2C	\$1,797	89.5	18.26	1.15	3.90	222	TH
	1200	213TC	575 V	PX6N003-5C	\$1,797	89.5	18.26	1.15	3.10	222	TH
5	3600	184TC	230/460 V	PX2N005-2C	\$1,427	88.5	15.91	1.15	5.80	145	TH
	3600	184TC	575 V	PX2N005-5C	\$1,427	88.5	15.91	1.15	4.60	145	TH
	1800	184TC	230/460 V	PX4N005-2C	\$1,427	89.5	15.91	1.15	6.20	145	TH
	1800	184TC	575 V	PX4N005-5C	\$1,427	89.5	15.91	1.15	4.90	145	TH
	1200	215TC	230/460 V	PX6N005-2C	\$2,039	90.2	19.76	1.15	6.40	246	TH
	1200	215TC	575 V	PX6N005-5C	\$2,039	90.2	19.76	1.15	5.10	246	TH
7.5	3600	213TC	230/460 V	PX2N7.5-2C	\$1,742	89.5	18.26	1.15	9.00	222	TH
	3600	213TC	575 V	PX2N7.5-5C	\$1,742	89.5	18.26	1.15	7.20	222	TH
	1800	213TC	230/460 V	PX4N7.5-2C	\$1,818	91.7	18.26	1.15	8.80	222	TH
	1800	213TC	575 V	PX4N7.5-5C	\$1,818	91.7	18.26	1.15	7.00	222	TH
	1200	254TC	230/460 V	PX6N7.5-2C	\$2,489	91	23.78	1.15	9.40	365	TH
	1200	254TC	575 V	PX6N7.5-5C	\$2,489	91	23.78	1.15	7.50	365	TH
10	3600	215TC	230/460 V	PX2N010-2C	\$1,996	90.2	19.76	1.15	11.90	246	TH
	3600	215TC	575 V	PX2N010-5C	\$1,996	90.2	19.76	1.15	9.50	246	TH
	1800	215TC	230/460 V	PX4N010-2C	\$2,039	91.7	19.76	1.15	11.70	246	TH
	1800	215TC	575 V	PX4N010-5C	\$2,039	91.7	19.76	1.15	9.30	246	TH
	1200	256TC	230/460 V	PX6N010-2C	\$2,893	91	25.52	1.15	12.60	411	TH
	1200	256TC	575 V	PX6N010-5C	\$2,893	91	25.52	1.15	10.10	411	TH
15	3600	254TC	230/460 V	PX2N015-2C	\$2,629	91	23.78	1.15	16.80	365	TH
	3600	254TC	575 V	PX2N015-5C	\$2,629	91	23.78	1.15	13.40	365	TH
	1800	254TC	230/460 V	PX4N015-2C	\$2,629	92.4	23.78	1.15	17.90	365	TH
	1800	254TC	575 V	PX4N015-5C	\$2,629	92.4	23.78	1.15	14.30	365	TH
	1200	284TC	230/460 V	PX6N015-2C	\$3,857	91.7	26.80	1.15	18.50	525	TH
	1200	284TC	575 V	PX6N015-5C	\$3,857	91.7	26.80	1.15	14.70	525	TH
20	3600	256TC	230/460 V	PX2N020-2C	\$2,969	91	25.52	1.15	22.40	411	TH
	3600	256TC	575 V	PX2N020-5C	\$2,969	91	25.52	1.15	17.80	411	TH
	1800	256TC	230/460 V	PX4N020-2C	\$3,020	93	25.52	1.15	23.60	411	TH
	1800	256TC	575 V	PX4N020-5C	\$3,020	93	25.52	1.15	18.80	411	TH
	1200	286TC	230/460 V	PX6N020-2C	\$4,477	91.7	28.30	1.15	24.30	565	TH
	1200	286TC	575 V	PX6N020-5C	\$4,477	91.7	28.30	1.15	19.40	565	TH

Discount Category **20**

Explosion Proof NEMA 143TC-445TC - TEFC C-Face With Feet - Cast Iron



HP	RPM	Frame	Voltage	P/N	List	FL Eff.	C Dim. (IN)	S.F. 60 Hz	FL Amps	LBS	Notes
25	3600	284TSC	230/460 V	PX2N025-2C	\$3,933	91.7	25.43	1.15	27.70	525	TH
	3600	284TSC	575 V	PX2N025-5C	\$3,933	91.7	25.43	1.15	22.20	525	TH
	1800	284TC	230/460 V	PX4N025-2C	\$3,959	93.6	26.93	1.15	29.40	525	TH
	1800	284TC	575 V	PX4N025-5C	\$3,959	93.6	26.93	1.15	23.50	525	TH
	1200	324TC	230/460 V	PX6N025-2C	\$5,739	93	29.93	1.15	30.30	750	TH
	1200	324TC	575 V	PX6N025-5C	\$5,739	93	29.93	1.15	24.20	750	TH
30	3600	286TSC	230/460 V	PX2N030-2C	\$4,418	92.4	26.93	1.15	33.00	565	TH
	3600	286TSC	575 V	PX2N030-5C	\$4,418	92.4	26.93	1.15	26.40	565	TH
	1800	286TC	230/460 V	PX4N030-2C	\$4,473	93.6	28.30	1.15	35.10	565	TH
	1800	286TC	575 V	PX4N030-5C	\$4,473	93.6	28.30	1.15	28.00	565	TH
	1200	326TC	230/460 V	PX6N030-2C	\$6,635	93	31.42	1.15	36.40	823	TH
	1200	326TC	575 V	PX6N030-5C	\$6,635	93	31.42	1.15	29.10	823	TH
40	3600	324TSC	230/460 V	PX2N040-2C	\$5,722	93	28.43	1.15	44.30	750	TH
	3600	324TSC	575 V	PX2N040-5C	\$5,722	93	28.43	1.15	35.40	750	TH
	1800	324TC	230/460 V	PX4N040-2C	\$5,743	94.1	29.93	1.15	46.60	750	TH
	1800	324TC	575 V	PX4N040-5C	\$5,743	94.1	29.93	1.15	37.20	750	TH
	1200	364TC	230/460 V	PX6N040-2C	\$8,572	94.1	32.57	1.15	46.30	995	TH
	1200	364TC	575 V	PX6N040-5C	\$8,572	94.1	32.57	1.15	37.00	995	TH
50	3600	326TSC	230/460 V	PX2N050-2C	\$6,834	93.6	29.92	1.15	55.00	823	TH
	3600	326TSC	575 V	PX2N050-5C	\$6,834	93.6	29.92	1.15	43.90	823	TH
	1800	326TC	230/460 V	PX4N050-2C	\$6,652	64.5	31.42	1.15	57.90	823	TH
	1800	326TC	575 V	PX4N050-5C	\$6,652	64.5	31.42	1.15	46.30	823	TH
	1200	365TC	230/460 V	PX6N050-2C	\$10,092	94.1	33.55	1.15	59.60	1074	TH
	1200	365TC	575 V	PX6N050-5C	\$10,092	94.1	33.55	1.15	47.60	1074	TH
60	3600	364TSC	230/460 V	PX2N060-2C	\$8,453	93.6	30.44	1.15	64.50	995	TH
	3600	364TSC	575 V	PX2N060-5C	\$8,453	93.6	30.44	1.15	51.60	995	TH
	1800	364TC	230/460 V	PX4N060-2C	\$8,559	95	32.57	1.15	67.20	995	TH
	1800	364TC	575 V	PX4N060-5C	\$8,559	95	32.57	1.15	53.70	995	TH
	1200	404TC	230/460 V	PX6N060-2C	\$12,535	94.5	36.50	1.15	69.10	1465	TH
	1200	404TC	575 V	PX6N060-5C	\$12,535	94.5	36.50	1.15	55.30	1465	TH
75	3600	365TSC	230/460 V	PX2N075-2C	\$10,742	93.6	31.42	1.15	80.70	1074	TH
	3600	365TSC	575 V	PX2N075-5C	\$10,742	93.6	31.42	1.15	64.50	1074	TH
	1800	365TC	230/460 V	PX4N075-2C	\$10,075	95.4	33.55	1.15	83.60	1074	TH
	1800	365TC	575 V	PX4N075-5C	\$10,075	95.4	33.55	1.15	66.90	1074	TH
	1200	405TC	230/460 V	PX6N075-2C	\$13,240	94.5	37.99	1.15	85.90	1465	TH
	1200	405TC	575 V	PX6N075-5C	\$13,240	94.5	37.99	1.15	68.70	1465	TH
100	3600	405TSC	230/460 V	PX2N100-2C	\$14,684	94.5	34.99	1.15	108.00	1465	TH
	3600	405TSC	575 V	PX2N100-5C	\$14,684	94.5	34.99	1.15	86.10	1465	TH
	1800	405TC	230/460 V	PX4N100-2C	\$13,240	95.4	37.99	1.15	109.00	1465	TH
	1800	405TC	575 V	PX4N100-5C	\$13,240	95.4	37.99	1.15	87.20	1465	TH
	1200	444TC	230/460 V	PX6N100-2C	\$17,602	95	44.40	1.15	118.00	1705	TH
	1200	444TC	575 V	PX6N100-5C	\$17,602	95	44.40	1.15	94.40	1705	TH
125	3600	444TSC	460 V	PX2N125-9C	\$18,770	95	40.65	1.15	137.00	1705	TH
	3600	444TSC	575 V	PX2N125-5C	\$18,770	95	40.65	1.15	109.00	1705	TH
	1800	444TC	460 V	PX4N125-9C	\$17,606	95.4	44.40	1.15	139.00	1705	TH
	1800	444TC	575 V	PX4N125-5C	\$17,606	95.4	44.40	1.15	111.00	1705	TH
	1200	445TC	460 V	PX6N125-9C	\$21,672	95	46.40	1.15	184.00	1775	TH
	1200	445TC	575 V	PX6N125-5C	\$21,672	95	46.40	1.15	147.00	1775	TH
150	3600	445TSC	460 V	PX2N150-9C	\$21,196	95	42.65	1.15	164.00	1775	TH
	3600	445TSC	575 V	PX2N150-5C	\$21,196	95	42.65	1.15	131.40	1775	TH
	1800	445TC	460 V	PX4N150-9C	\$21,404	95.8	46.40	1.15	165.00	1775	TH
	1800	445TC	575 V	PX4N150-5C	\$21,404	95.8	46.40	1.15	131.70	1775	TH

Discount Category **20**

Single Phase
Fractional 56/56C
NEMA Aluminum
NEMA Cast Iron
NEMA Explosion Proof
Close Coupled Pump Motor
NEMA 2 Speed Motor
NEMA Brake Motor

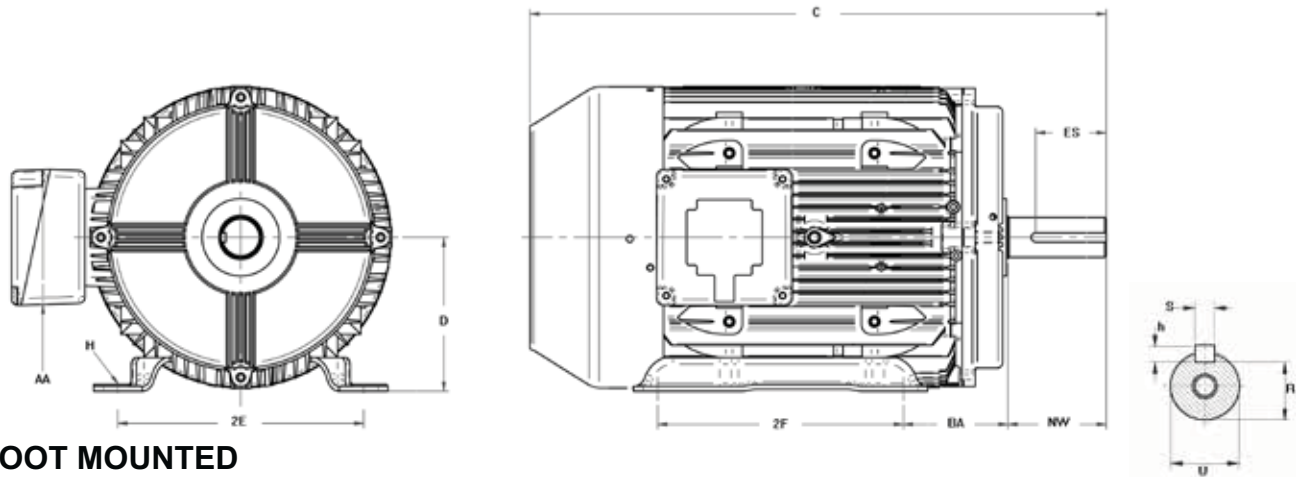

FOOT MOUNTED

Frame Size	FOOT INSTALLATION DIM.				SHAFT INSTALLATION DIM.						GENERAL DIM.	
	2E	2F	H	BA	N-W	U	S	AH	R	ES	D	AA
56	4.87	3.0	0.34	2.75	1.875	0.625	0.187	2.062	0.517	1.37	3.50	0.50
143T	5.5	4.0	0.34	2.25	2.25	0.875	0.187	2.125	0.771	1.37	3.50	0.75
145T		5.0	0.34	2.25	2.25	0.875	0.187	2.125	0.771	1.37	3.50	0.75
182T	7.5	4.5	0.50	2.75	2.75	1.125	0.25	2.625	0.986	1.88	4.50	0.75
184T		5.5	0.50	2.75	2.75	1.125	0.25	2.625	0.986	1.88	4.50	0.75
213T	8.5	5.5	0.50	3.50	3.375	1.375	0.312	3.125	1.201	2.38	5.25	1.00
215T		7.0	0.50	3.50	3.375	1.375	0.312	3.125	1.201	2.38	5.25	1.00
254T	10	8.25	0.59	4.25	4.00	1.625	0.375	3.75	1.416	2.87	6.25	1.25
256T		10	0.59	4.25	4.00	1.625	0.375	3.75	1.416	2.87	6.25	1.25
284T	11	9.5	0.59	4.75	4.625	1.875	0.50	4.375	1.591	3.25	7.00	1.50
284TS		9.5	0.59	4.75	3.25	1.625	0.375	3.00	1.416	1.87	7.00	1.50
286T	11	11	0.59	4.75	4.625	1.875	0.50	4.375	1.591	3.25	7.00	1.50
286TS		11	0.59	4.75	3.25	1.625	0.375	3.00	1.416	1.87	7.00	1.50
324T	12.5	10.50	0.63	5.25	5.25	2.13	0.50	5.00	1.845	4.75	8.00	2.00
324TS		10.50	0.63	5.25	3.75	1.88	0.50	3.50	1.591	3.25	8.00	2.00
326T	12.5	12	0.63	5.25	5.25	2.13	0.50	5.00	1.845	4.75	8.00	2.00
326TS		12	0.63	5.25	3.75	1.88	0.50	3.50	1.591	3.25	8.00	2.00
364T	14	11.25	0.63	5.88	5.88	2.38	0.63	5.38	2.021	5.00	9.00	3.00
364TS		11.25	0.63	5.88	3.75	1.88	0.50	3.50	1.591	3.25	9.00	3.00
365T	14	12.25	0.63	5.88	5.88	2.38	0.63	5.38	2.021	5.00	9.00	3.00
365TS		12.25	0.63	5.88	3.75	1.88	0.50	3.50	1.591	3.25	9.00	3.00
404T	16	12.25	0.75	6.63	7.25	2.88	0.75	7.25	2.450	6.50	10.00	3.00
404TS		12.25	0.75	6.63	4.25	2.13	0.50	4.00	1.845	3.25	10.00	3.00
405T	16	13.75	0.75	6.63	7.25	2.88	0.75	7.25	2.450	6.50	10.00	3.00
405TS		13.75	0.75	6.63	4.25	2.13	0.50	4.00	1.845	3.25	10.00	3.00
444T	18	14.50	0.75	7.50	8.50	3.38	0.88	8.25	2.880	7.00	11.00	3.00
444TS		14.50	0.75	7.50	4.75	2.38	0.63	4.50	2.021	4.13	11.00	3.00
445T	18	16.50	0.75	7.50	8.50	3.38	0.88	8.25	2.880	7.00	11.00	3.00
445TS		16.50	0.75	7.50	4.75	2.38	0.63	4.50	2.021	4.13	11.00	3.00
447T	18	20	0.75	7.50	8.50	3.38	0.88	8.25	2.880	7.00	11.00	3.00
447TS		20	0.75	7.50	4.75	2.38	0.63	4.50	2.021	4.13	11.00	3.00
504Z	20	16	1.00	8.50	9.25	3.63	0.88	9.00	3.134	8.50	12.50	3.00
504SZ		16	1.00	8.50	5.50	2.75	0.63	5.25	2.402	4.88	12.50	3.00
505Z	20	18	1.00	8.50	9.25	3.63	0.88	9.00	3.134	8.50	12.50	3.00
505SZ		18	1.00	8.50	5.50	2.75	0.63	5.25	2.402	4.88	12.50	3.00
585Z	24	20	1.00	10.00	10.00	3.88	1.00	10.00	3.309	9.75	14.50	3.00
585SZ		20	1.00	10.00	7.75	3.00	0.75	7.75	2.569	7.75	14.50	3.00
586Z	24	22	1.00	10.00	10.00	3.88	1.00	10.00	3.309	9.75	14.50	3.00
586SZ		22	1.00	10.00	7.75	3.00	0.75	7.75	2.569	7.75	14.50	3.00

NEMA TEFC Dimensions Frame Sizes 56 - 586

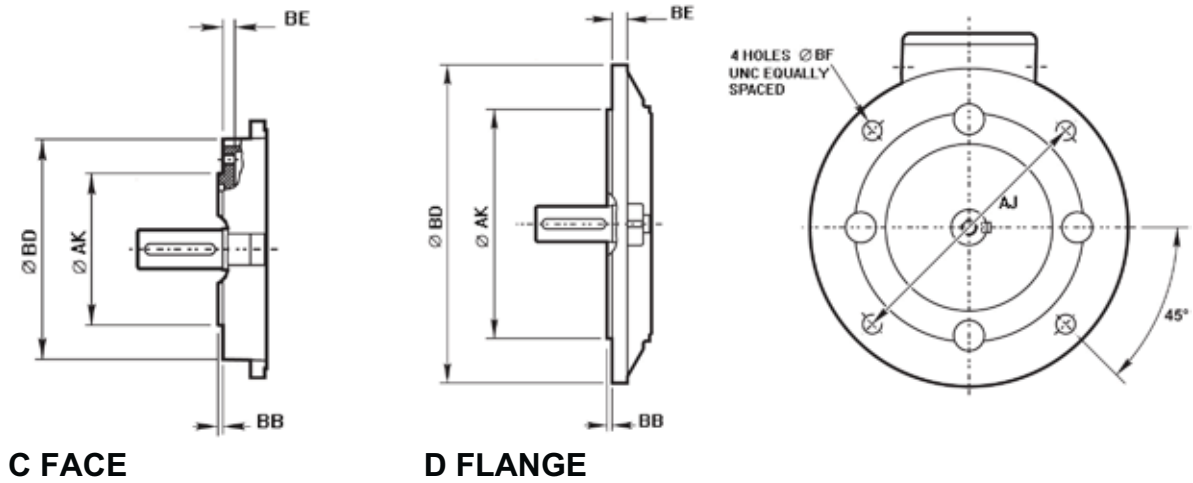

Frame Size	D FLANGE DIMENSIONS					C FACE DIMENSIONS				
	AJ	AK	BB	BD	BF	AJ	AK	BB	BD	BF
56	-	-	-	-	-	5.87	4.5	0.12	6.5	0.37
143T	10	9	0.25	11	0.53	5.87	4.5	0.12	6.5	0.37
145T										
182T	10	9	0.25	11	0.53	7.25	8.5	0.16	9	0.50
184T								0.25	6.5	
182TCH	-	-	-	-	-	5.88	4.5	0.16	6.5	0.38
184TCH								0.25		
213T	10	9	0.25	11	0.53	7.25	8.5	0.25	9	0.50
215T										
254T	12.50	11	0.25	14	0.81	7.25	8.5	0.25	9.84	0.50
256T										
284T	12.50	11	0.25	14	0.81	9	10.5	0.25	11.25	0.50
286T										
284TS	12.50	11	0.25	14	0.81	9	10.5	0.25	11.25	0.50
286TS										
324T	16	14	0.25	17.75	0.81	11	12.50	0.25	13	0.63
326T										
324TS	16	14	0.25	17.75	0.81	11	12.50	0.25	13	0.63
326TS										
364T	16	14	0.25	17.75	0.81	11	12.50	0.25	13.75	0.63
365T										
364TS	16	14	0.25	17.75	0.81	11	12.50	0.25	13.75	0.63
365TS										
404T	20	18	0.25	21.63	0.81	11	12.50	0.25	14.50	0.63
405T										
404TS	20	18	0.25	21.63	0.81	11	12.50	0.25	14.50	0.63
405TS										
444T	20	18	0.25	21.63	0.81	14	16	0.25	17.50	0.63
445T										
444TS	20	18	0.25	21.63	0.81	14	16	0.25	17.50	0.63
445TS										
447T	20	18	0.25	21.63	0.81	14	16	0.25	17.50	0.63
449T										
447TS	20	18	0.25	21.63	0.81	14	16	0.25	17.50	0.63
449TS										
504SZ	22	18	0.25	25	0.94	14.50	16.50	0.25	17.50	0.63
504Z										
505SZ	22	18	0.25	25	0.94	14.50	16.50	0.25	17.50	0.63
505Z										
585SZ	29.13	26.77	0.25	31.50	0.94	-	-	-	-	-
585Z										
586SZ	29.13	26.77	0.25	31.50	0.94	-	-	-	-	-
586Z										

**Definition
IP (Ingress Protection)
IEC Metric Motors**



Protection Against Solid Objects			Protection Against Liquids		
#	Brief Description*	Definitions	#	Brief Description*	Definitions
0	Non-protected machines	No special protection	0	Non-protected machines	No special protection
1	Machine protected against solid objects greater than 50 mm**	Accidental or inadvertent contact with or approach to live and moving parts inside the enclosure by a large surface of the human body, such as a hand (but no protection against deliberate access). Ingress of solid objects exceeding 50 mm in diameter	1	Machine protected against dripping water	Dripping water (vertically falling drops) shall have no harmful effect.
2	Machine protected against solid objects greater than 12 mm**	Contact by fingers or similar objects not exceeding 80 mm in length with or approach to live or moving parts inside the enclosure. Ingress of solid objects exceeding 12 mm in diameter.	2	Machine protected against dripping water when tilted up to 15°	Vertically dripping water shall have no harmful effect when the machine is tilted in any angle up to 15° from its normal position
3	Machine protected against solid objects greater than 2.5 mm**	Contact with or approach to live or moving parts inside the enclosure by tools or wires exceeding 2.5 mm in diameter. Ingress of solid objects exceeding 1 mm in diameter.	3	Machine protected against spraying water	Vertically dripping water shall have no harmful effect when the machine is tilted in any angle up to 15° from its normal position
4	Machine protected against solid objects greater than 1mm**	Contact with or approach to live or moving parts inside the enclosure by wires or strips of thickness greater than 1 mm in diameter.	4	Machine protected against splashing water	Water falling as a spray at any angle up to 60° from the vertical shall have no harmful effect
5	Dust-protected machine†	Contact with or approach to live or moving parts inside the enclosure. Ingress of dust is not totally prevented but dust does not enter insufficient quantity to interfere with satisfactory operation of the machine.	5	Machine protected against water jets	Water projected by a nozzle against the machine from any direction shall have no harmful effect.
6	Dust-tight machine†	Contact with or approach to live or moving parts inside the enclosure. No ingress of dust	6	Machine protected against heavy seas	Water from heavy seas or water projected in powerful jets shall not enter the machine in harmful quantities.

* The brief description given in column 2 on this table should not be used to specify the form of protection.

** Machines assigned a first characteristic number 1,2,3 or 4 will exclude both regularly or irregularly shaped solid objects proved that three normally per pendicular dimensions of the object exceed the appropriate figure in column "Definition".

† The degree of protection against dust defined by this standard is a general one. When the nature (dimensions of particles, their nature, for instance fibrous particles) is specified, test conditions should be determined by an agreement between manufacturer and user.

IEC Mounting Codes

Horizontal shaft:

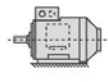

IM B3
IM 1001
foot mounted

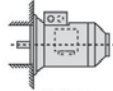

IM B5
IM 3001
flange at DE
no feet



IM B6
IM 1051
foot wall mounted with
feet on left-hand side
when viewed from DE



IM B7
IM 1061
foot wall mounted with
feet on right-hand side
when viewed from DE



IM B8
IM 1071
ceiling mounted
with feet
above motor

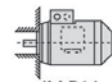

IM B14
IM 3601
face at DE
no feet

Vertical shaft:

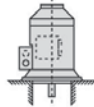

IM V1
IM 3011
flange at DE
shaft down
no feet

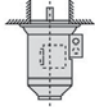

IM V3
IM 3031
flange at DE
shaft up
no feet

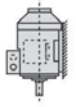

IM V5
IM 1011
vertical foot
wall mounted
shaft down

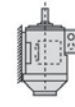

IM V6
IM 1031
vertical foot
wall mounted
shaft up

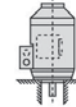

IM V18
IM 3611
face at DE
shaft down
no feet

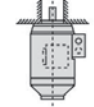

IM V19
IM 3631
face at DE
shaft up
no feet

NEMA Mounting Codes

FLOOR MOUNTINGS



ASSEMBLY F-1

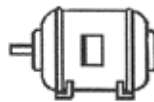

ASSEMBLY F-2



ASSEMBLY F-3

WALL MOUNTINGS



ASSEMBLY W-1

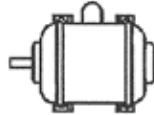

ASSEMBLY W-2



ASSEMBLY W-3

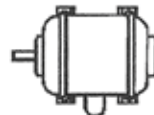

ASSEMBLY W-4



ASSEMBLY W-5

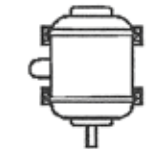

ASSEMBLY W-6

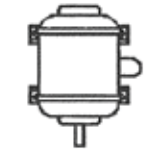

ASSEMBLY W-7

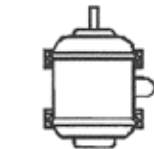

ASSEMBLY W-8

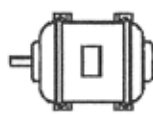

ASSEMBLY W-9

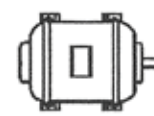

ASSEMBLY W-10



ASSEMBLY W-11



ASSEMBLY W-12

CEILING MOUNTINGS



ASSEMBLY C-1

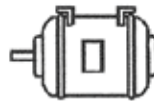

ASSEMBLY C-2



ASSEMBLY C-3