

TOTALLY ENCLOSED FAN-COOLED TYPE, SUIRREL-CAGE ROTOR

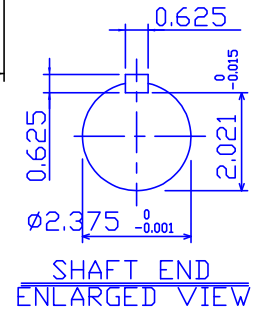
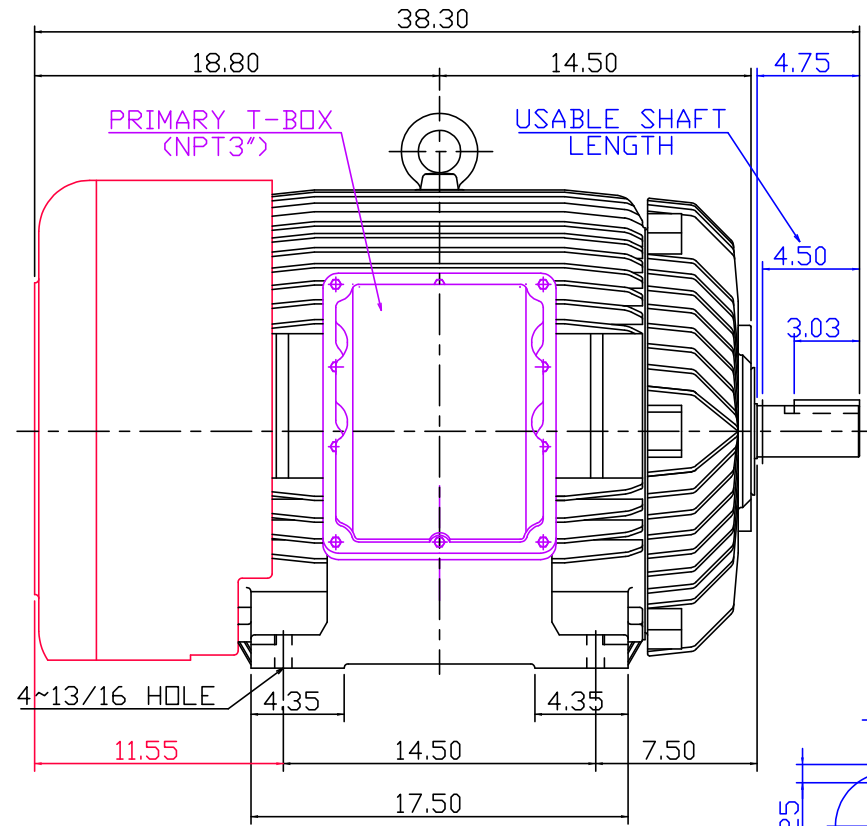
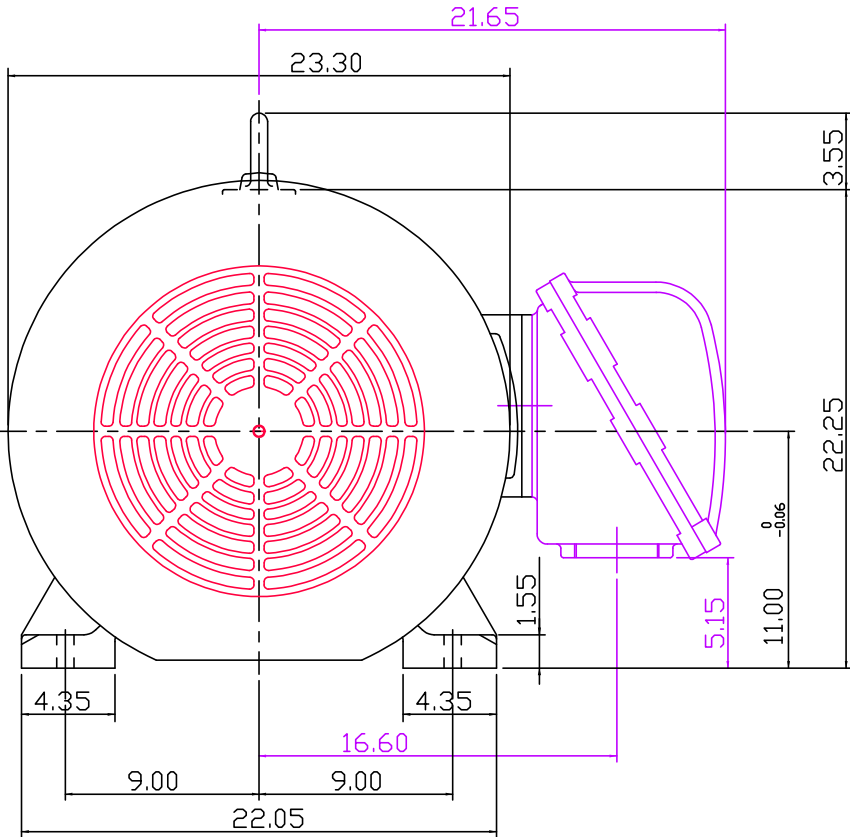

- NOTE:
1. DIMENSIONS IN INCHES
 2. FRAME NO. 444TS
 3. F CLASS INSULATION, S.F. 1.15
 4. FOR DIRECT FLEXIBLE COUPLING
 5. ENCLOSURE: IP44
 6. BEARING NO.: DRIVE END 6313C3,
OPP. DRIVE END 6313C3
 7. UL EXPLOSION PROOF
 8. NON-SPARKING FAN
 9. WITH THERMOSTAT : N.C. 145°C 3PCS
 10. APPROX. WEIGHT: 1430 LBS

DATE	OUTLINE DIMENSIONS	
	3-PHASE INDUCTION MOTOR	
BROOK CROMPTON		DWG NO. REV: 00

TX-56C